

Operating Manual

HPP06 Hydraulic Powerpack

From serial
No. 17522

Prior to Operation

We thank you for choosing a HYCON powerpack.

Please note that the powerpack is delivered without hydraulic oil, and therefore it must be filled up with hydraulic oil prior to operation.

To ensure smooth operation and long-lasting performance of your new powerpack, we recommend you to study this operating manual carefully and pay special attention to the

Safety and Service Precautions

We hope you will be satisfied with your new HYCON powerpack.

Best regards
HYCON A/S

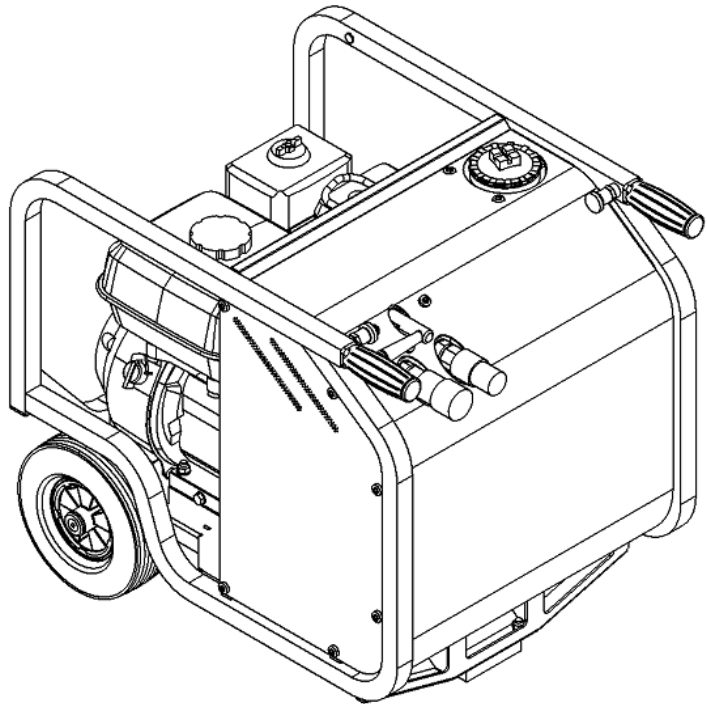

HYCON A/S
Juelstrupparken 11
DK-9530 Støvring
Danmark

Tel: +45 9647 5200
Fax: +45 9647 5201
Mail hycon@hycon.dk
www.hycon.dk

Contents

	Page
Safety precautions.....	2
Filling up hydraulic oil	2
Technical data.....	3
Starting instructions.....	4
Service, maintenance and hydraulic settings	4
Trouble shooting	5
Oil types	7
EC-Declaration of Conformity	8
Warranty Terms	9
Spare parts list	10

Safety Precautions

1. Always use protective earplugs. The powerpack complies with the EU noise limits, but by daily long-lasting operation there is a risk of hearing defects.
2. Always connect hoses before starting.
3. Never add fuel and oil when the engine is running.
4. In case of non-operation or performance of service, always turn off the engine.
5. Never start the engine without side covers.
6. Operation of the powerpack without tool connected and with lever at "ON" may cause overheating of the system and damage to the powerpack.
7. When lifting the powerpack from a vehicle, we recommend the use of a crane.
8. The pressure relief valve is set at 110 bar from our plant. Never set it higher.
9. Always use filters with by-pass. The use of filters without by-pass may blow the hydraulic hoses and the filter cover.

Filling Up Hydraulic Oil

- To fill up with hydraulic oil, loosen the filter cover on top of the powerpack.
- Remove the filter element (see photo), and fill up with oil. When oil is showing at the bottom of the filter unit, there is enough oil on the powerpack.
- Insert the filter element again, mount the cover and the powerpack is ready for use.

Please note: When connecting new extension hoses, it is necessary to fill up with extra 2 litres of oil. Therefore always top up the powerpack when connecting new extension hoses.



Technical Data

Hydraulics

The powerpack is mounted with a pressure relief valve to avoid a too high pressure. Furthermore, the very efficient air cooling protects the powerpack against super-heating.

	Metric	Imperial
Oil flow at 3300 rpm	18 l.p.m	4.8 g.p.m.
Pressure relief valve setting	110 bar	1600 psi
Pump type	Gear pump	
Oil temperature max	70° C	160° F
Hydraulic oil tank capacity Min/Max	5 litres/7 litres	1.3 gallon/1,8 gallon
Petrol tank capacity	3.1 litres	0.8 gallon
Hydraulic system compl.	Max. 8 litres	Max 2.1 gallon
Filter system (filter element)	25 Micron with by-pass	
Engine	Honda GX200QX7 6.5 HP (gross power) 4-stroke petrol with oil alert system Petrol - normal or unleaded Engine oil 1.1 litres	

	Metric	Imperial
Guaranteed sound power level L_{WA}	101 dB	
Nominal pressure	100 bar	1450 psi
Nominal flow	20 l.p.m	5,0 g.p.m.
Dimensions (LxWxH) mm/inch	647x490x568	25x19x22
Weight, without hydraulic oil	58 kg	128 lbs

Starting Instructions

Please observe the starting instructions on the front of the powerpack.

- Start:**
- Check engine oil level
 - Check hydraulic oil level at sight glass
 - Connect hoses and tool
 - Switch fuel tap to "ON"
 - Activate choke
 - Turn ignition switch to "1"
 - Pull recoil starter
 - Move the lever to "ON"
- Stop:**
- Move the lever to "OFF"
 - Turn off the ignition switch
 - Turn the fuel tap to "OFF"

Service, Maintenance and Hydraulic Settings

Service/Maintenance	Daily	Weekly	Yearly
Engine oil	Check		1 x replacement
Hydraulic oil	Check		1 x replacement
Hydraulic oil filter *)			1 x replacement
Check hoses		(tighten up if needed)	
Air filter			1 x replacement
Fuel filter			1 x replacement

*) Use only filters with by-pass

Hydraulic Settings

Check the working pressure by means of test equipment. The test equipment must comprise a pressure gauge, a flow meter and a valve for adjustment of pressure.

The pressure relief valve is placed on the right side of the valve block.

1. Connect the test equipment, start the powerpack and move the lever to "ON". Then close the valve - the pressure gauge must show 110 bar.

Adjust the pressure relief valve by loosening the lock nut and turning the adjustment screw in or out. "In" increases the pressure, and "out" decreases the pressure.

Retighten the lock nut after adjustment.

2. When the pressure relief valve has been adjusted correctly, the working pressure must be set at 100 bar by means of the valve on the test equipment. At 100 bar, the oil flow should be 18 l. p.m.

If correct pressure/oil flow cannot be achieved by following the above instructions, the powerpack must be re-adjusted. If the pressure/oil flow is then still incorrect, the pump is defect and must be replaced.

Trouble Shooting

Start by checking the hydraulic settings



Before starting, check the oil level at the sight glass.

Check the working pressure by means of the test equipment. The test equipment comprises a pressure gauge, a flow meter and a valve for adjustment of pressure.

The pressure relief valve is placed on the right side of the valve block.

1. Connect the test equipment, start the powerpack and move the lever to "ON". Then close the valve - the pressure gauge must show 110 bar.

If the pressure relief valve does not show 110 bar, adjust the valve by loosening the lock nut and turning the adjustment screw in or out. "In" increases the pressure, and "out" decreases the pressure.

Retighten the lock nut after adjustment.

2. When the pressure relief valve has been adjusted correctly, the working pressure must be set at 100 bar by means of the valve on the test equipment. At 100 bar, the oil flow should be 18 l. p.m. Adjust the flow on the powerpack by means of the max. r.p.m. adjustment screw.
3. The number of revolutions must not exceed 3300 r.p.m. at 18 l.p.m. If the number is higher, there may be dirt in the pressure relief valve, or the pump may be worn.

**r.p.m. meter
Item No. 9992124**



Problem	Cause	Solution
Powerpack does not give the right oil flow, or r.p.m. is too high	Pressure relief valve may be clogged up or set incorrectly	Dismount pressure relief valve and clean with compressed air, or correct the setting of the valve
	Pump is worn	Replace pump
The maximum pressure of the powerpack is too high	Wrong adjustment of pressure relief valve	Adjust pressure relief valve to 110 bar (see instructions above)
Hydraulic oil is foaming, and oil is leaking at the air filter on the filter housing	Leaking shaft seal in pump	Replace pump
	Oil level too low	Add oil
	Heavy vibrations because of defective fan blade or defective rubber dampers	Replace defective parts
	Too much oil in tank	Drain off oil from tank
Engine does not start		See engine manual

Oil Types

The HYCON power packs use standard hydraulic oil, i.e. all types of mineral oil and biodegradable oil, which comply with the following values:

Ambient temperature range	Below 10°C 50°F	10 ... 30°C 50 ... 86°F	Above 30°C 86°F
Recommended oil viscosity grade	VG 32	VG 46	VG 68

Recommended oil cleanliness		ISO 4406 /19/16 / NAS 1638 10
Permitted viscosity	cSt	10 – 600
Viscosity index	Minimum	100
Oil temperature area	°C /°F	-20 to 70 / -4 to 158



EC-Declaration of Conformity

HYCON A/S

Juelstrupparken 11
DK-9530 Støvring
Denmark

Tel: +45 9647 5200

Fax: +45 9647 5201

Mail hycon@hycon.dk

www.hycon.dk

We hereby declare that

HPP06 hydraulic powerpack – from serial No. 17522
(with 4.8 kW petrol engine)

is manufactured in conformity with the EC Directives 2006/42/EC and 2000/14/EC.

Notified Body 2914:

Sweco Danmark A/S
Ørestads Boulevard 41
2300 København S
Danmark

Guaranteed sound power level: 101 dB

HYCON A/S
Juelstrupparken 11
DK-9530 Støvring
Denmark

A handwritten signature in blue ink, appearing to read "Martin Møller".

Martin Møller
Managing Director
22.04.2022

Warranty Terms

We grant 12 months warranty from the first date of operation – however, not more than 18 months from the date of delivery.

The warranty applies to faults that can be related to construction and production errors.

Faults caused by incorrect operation, incorrect handling, lack of maintenance or the like will not be accepted as warranty.

The warranty covers the parts necessary for repair and the suggested average time needed for repair.

For further warranty details, please contact your local dealer.