

# **Spare parts list**

## **Handheld core drills**

### **5, 15**

	Valid from serial number
COR 5	BGF0006875
COR 15	BGF0006875





# Contents

- General information** ..... 5
- Spare parts list** ..... 6
  - COR 5 ..... 6
  - COR 15 ..... 8
  - COR 5, COR 15 ..... 10
  - Optional parts ..... 12
- Core bits (Thread size 1<sup>1</sup>/<sub>4</sub> in. UNC)** ..... 16
- Kits** ..... 17
  - Seal kit ..... 17
  - Motor seal kit ..... 17
  - Water kit ..... 17
  - Chuck kit ..... 18



## General information

This spare parts list applies to the following:

Part number	Description
1806 1014 54	Handheld core drill Cor 5
1806 1014 55	Handheld core drill Cor 15

Use only authorized parts. Any damage or malfunction caused by the use of unauthorized parts is not covered by Warranty or Product Liability. Any unauthorized use or copying of the contents or any part thereof is prohibited. This applies in particular to trademarks, model denominations, part numbers, and drawings.

### Instructions for use

This spare parts list contains no safety regulations and is merely intended to assist in the ordering of spare parts.

For information about operating, servicing, or repairing, the relevant Safety and operating instructions must be consulted at all costs.

Please observe the safety instructions listed in the relevant Safety and operating instructions!

# Spare parts list

## COR 5

---

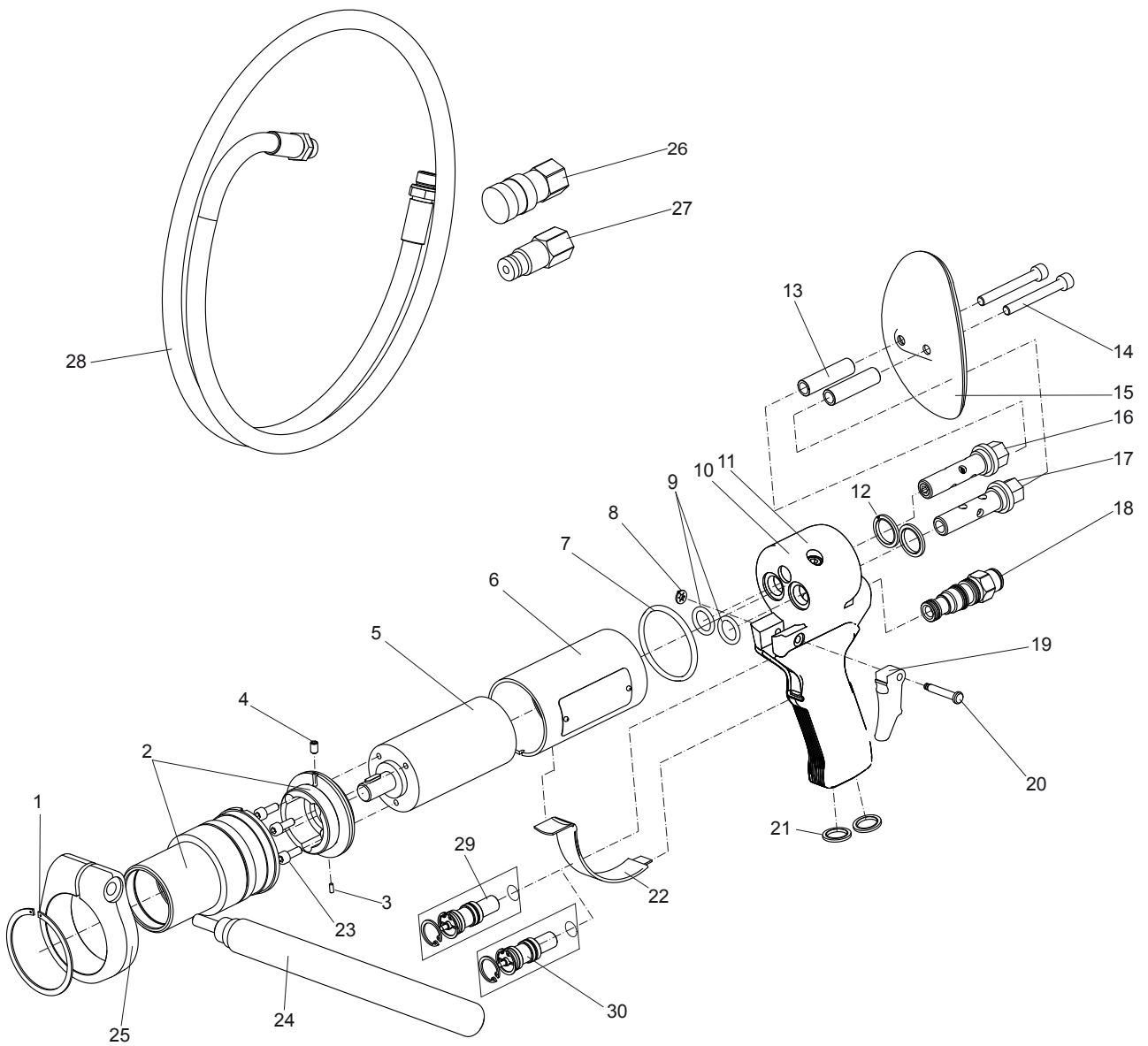

No.	Description	Remark	Quantity	Part number
1	Circlip	SP 72	1	3378 5120 23
2	Bearing housing	Included transition adaptor	1	3376 6080 02
3	Taper pin	M6 x 8 mm	1	3378 5122 80
4	Screw	M6 x 8 mm	1	3377 5007 18
5	Motor		1	3371 8177 46
6	Tube		1	3376 6081 32
7	O-ring	Ø58 x 4 mm (2.28 x 0.16 in.)	1	3378 5122 79
8	Washer	Star-lock Ø5 mm	1	3376 6081 39
9	O-ring	Ø58 x 4 mm (2.28 x 0.16 in.)	2	3378 5120 35
10	Handle, plugged with coating	COR 5 up to serial number 30058	1	3376 6080 01
11	Handle, plugged with coating	COR 5 from Serial number 30059	1	3376 6080 13
12	Seal ring	Bonded seal ½ in. bsp	2	3371 8057 14
13	Spacer		2	3376 6081 21
14	Screw	M8 x 65 mm	2	3378 3025 08
15	Breast plate		1	3376 6080 07
16	Hollow bolt		1	3376 6081 23
17	Hollow bolt		1	3376 6081 11
18	Relief valve	115 bar	1	3376 6081 61
19	Trigger		1	3376 6081 50
20	Pin		1	3376 6081 34
21	Seal ring	Bonded seal ½ in. bsp	2	3377 0163 75
22	Bracket		1	3376 6080 06
23	Screw	M8 x 15 mm	3	3371 8177 26
24	Handle		1	3376 6080 05
25	Handle ring		1	3376 6081 13
26	Quick release coupling	Female	1	3371 8051 37
27	Quick release coupling	Male	1	3371 8051 38
28	Hose	Male	1	3371 8030 76
29	Trigger, complete	COR 5 up to serial number 30058	1	3376 6080 03
30	Trigger, complete	COR 5 from Serial number 30059	1	3376 6080 15

# COR 15

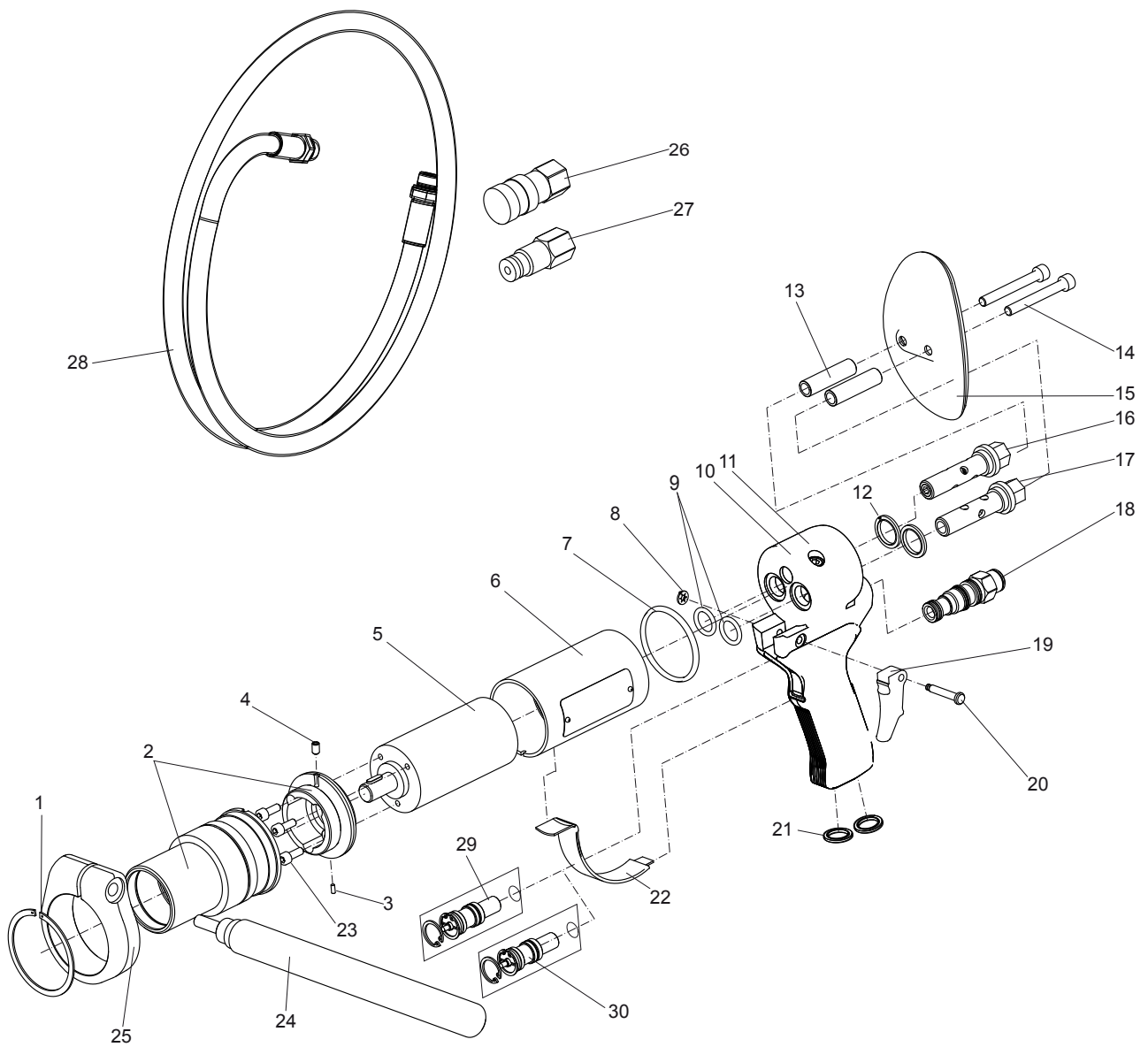



No.	Description	Remark	Quantity	Part number
1	Circlip	SP 72	1	3378 5120 23
2	Bearing housing	Included transition adaptor	1	3376 6080 02
3	Taper pin	Ø3 x 8 mm DIN 1B	1	3378 5122 80
4	Screw	M6 x 8 mm	1	3377 5007 18
5	Motor		1	3378 5120 96
6	Tube		1	3376 6081 31
7	O-ring	Ø58 x 4 mm (2.28 x 0.16 in.)	1	3378 5122 79
8	Washer	Star-lock Ø5 mm	1	3376 6081 39
9	O-ring	Ø58 x 4 mm (2.28 x 0.16 in.)	2	3378 5120 35
10	Handle, plugged with coating	COR 15 up to serial number 10009	1	3376 6080 01
11	Handle, plugged with coating	COR 15 from serial number 10010	1	3376 6080 13
12	Seal ring	Bonded seal ½ in. bsp	2	3371 8057 14
13	Spacer		2	3376 6081 21
14	Screw	M8 x 65 mm	2	3378 3025 08
15	Breast plate		1	3376 6080 07
16	Hollow bolt		1	3376 6081 23
17	Hollow bolt		1	3376 6081 11
18	Relief valve	127 bar	1	3376 6081 62
19	Trigger		1	3376 6081 50
20	Pin		1	3376 6081 34
21	Seal ring	Bonded seal ½ in. bsp	4	3377 0163 75
22	Bracket		1	3376 6080 06
23	Screw	M6 x 15 mm	3	3371 8177 26
24	Handle		1	3376 6080 05
25	Handle ring		1	3376 6081 13
26	Quick release coupling	Female	1	3371 8051 37
27	Quick release coupling	Male	1	3371 8051 38
28	Hose	Male	2	3371 8030 76
29	Trigger, complete	COR 15 up to serial number 10009	1	3376 6080 03
30	Trigger, complete	COR 15 from serial number 10010	1	3376 6080 15

# COR 5, COR 15

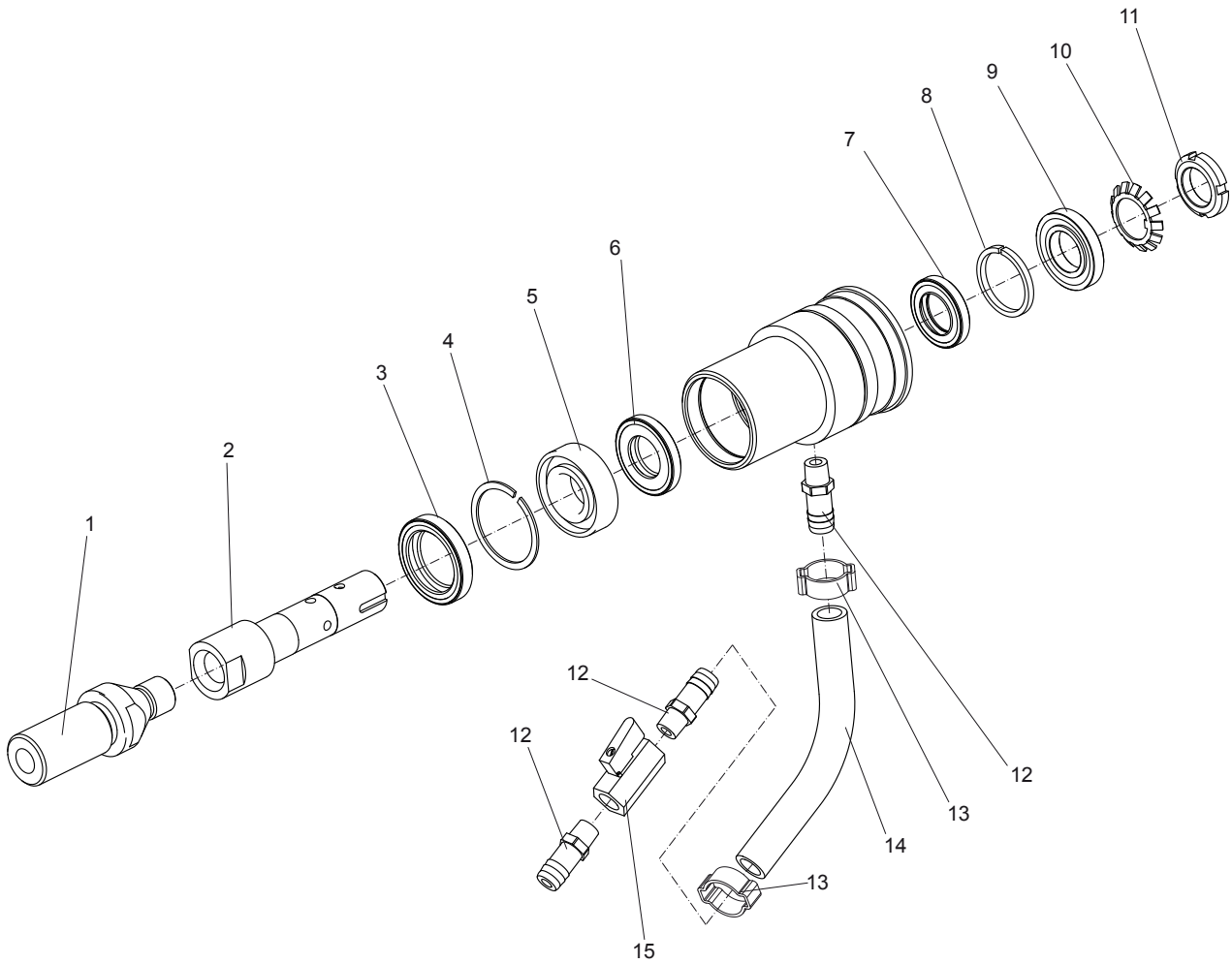

No.	Description	Remark	Quantity	Part number
1	Adaptor	½ in. BSP x 1- ¼ in. UNC	1	3378 5120 64
2	Shaft		1	3378 5122 72
3	Dust seal	Ø35 x 52 x 7 mm (1.38 x 2.05 x 0.27 in.)	1	3376 1007 21
4	Retainer		1	3378 5120 21
5	Bearing		1	3378 5120 17
6	Shaft seal	Ø25 x 47 x 6 mm (0.98 x 1.85 x 0.24 in.)	1	3376 1007 20
7	Shaft seal	Ø25 x 42 x 6 mm (0.98 x 1.65 x 0.24 in.)	1	3376 1007 19
8	Spacer		1	3378 5120 22
9	Bearing		1	3378 5120 18
10	Tab washer		1	3378 5122 77
11	Lock nut		1	3378 5122 73
12	Hose connection	¼ in. BSPT x ½ in. hose barb	3	3371 8097 46
13	Hose clamp	Ø20 - 23 mm Ø0.78 - 0.90 in.	2	3371 8037 70
14	Water hose	½ in.	1	3376 6081 60
15	Ball valve	¼ in. BSPT, Female	1	3378 5120 58

## Optional parts

### Trigger, complete

For COR 5 up to S/N 30058 and COR 15 up to S/N 10009

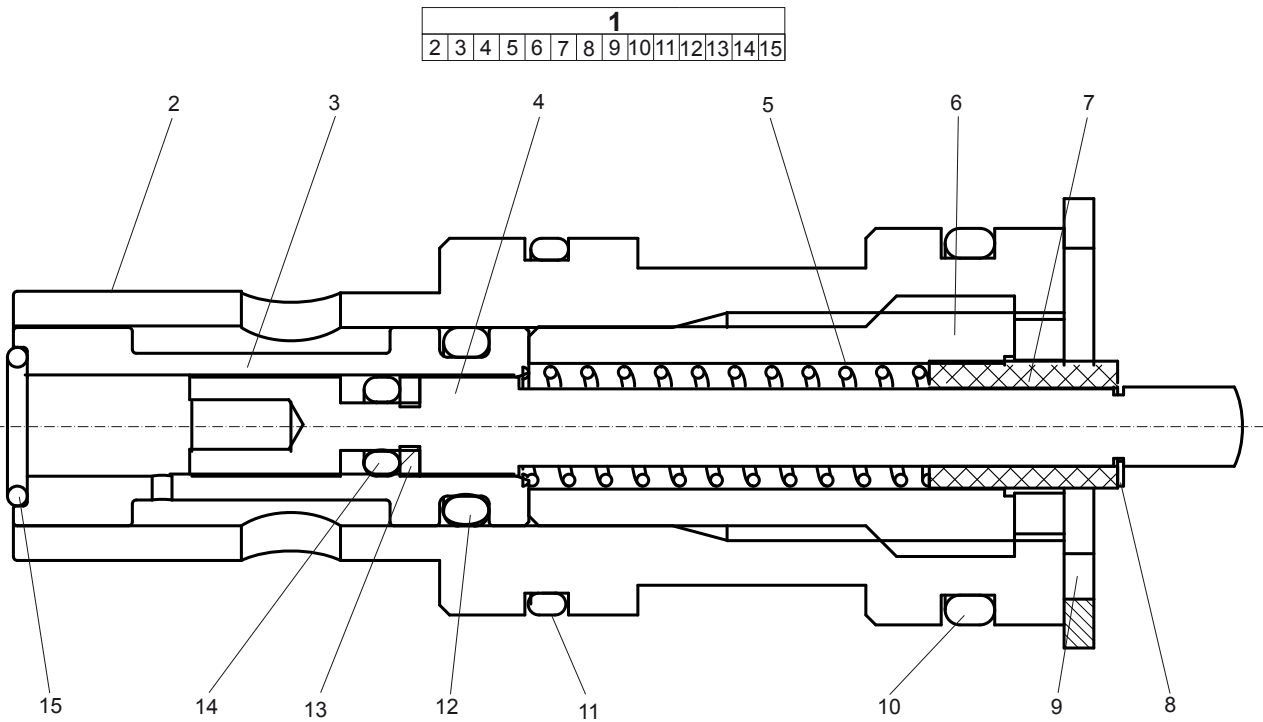

No.	Description	Remark	Quantity	Part number
1(2-15)	Trigger, complete		1	3376 6080 03
2	Trigger retainer		1	3376 6081 02
3	Valve housing		1	3376 6081 03
4	Spool		1	3378 5120 10
5	Spring		1	3378 5120 30
6	Guide		1	3378 5120 12
7	Bearing		1	3378 5120 13
8	Circlip	H4	1	3378 5120 63
9	Circlip	JS 22	1	3376 1008 10
10	O-ring	Ø16 x 2 mm (0.63 x 0.08 in.)	1	3377 0005 33
11	O-ring	Ø16 x 1.5 mm (0.63 x 0.06 in.)	1	3371 8207 26
12	O-ring	Ø6.3 x 1.8 mm (0.25 x 0.07 in.)	1	3378 5120 36
13	Stop ring		1	3378 5120 47
14	O-ring	Ø2 x 1.5 mm (0.08 x 0.06 in.)	1	3378 5120 37
15	O-ring	Ø6 x 1 mm (0.24 x 0.04 in.)	1	3376 1008 08

**Trigger, complete**

For COR 5 from S/N 30059 and COR 15 from S/N 10010

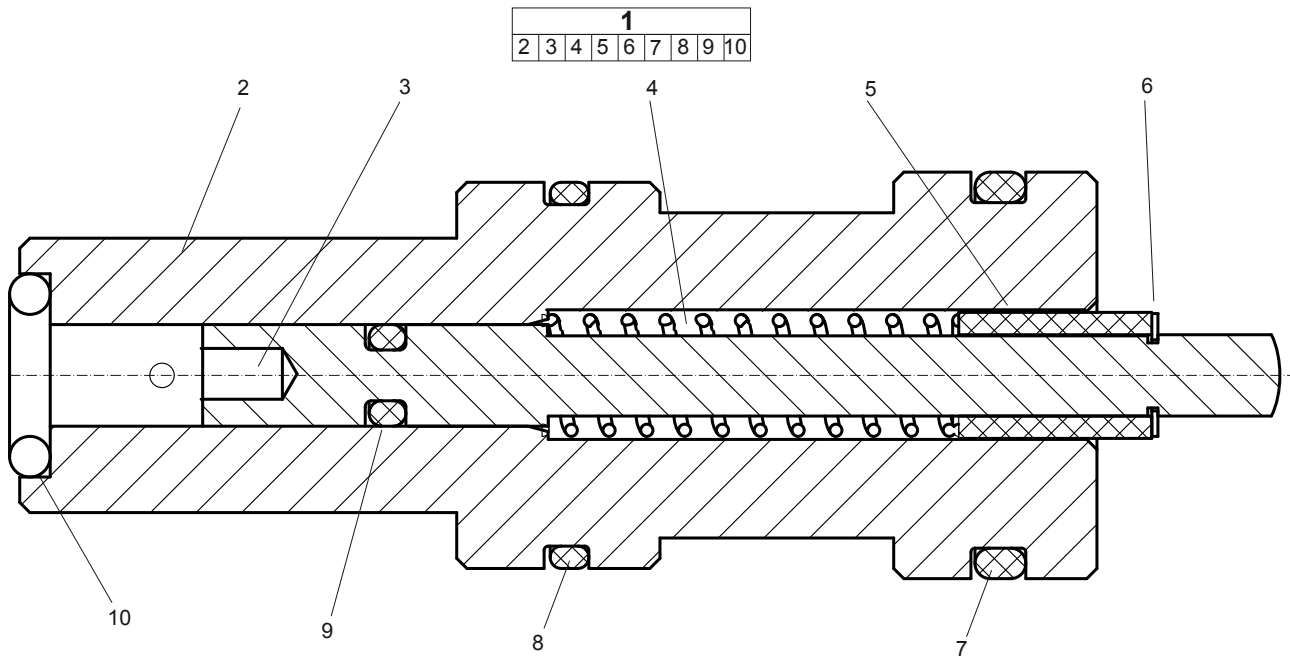

No.	Description	Remark	Quantity	Part number
1(2-10)	Trigger, complete		1	3376 6080 15
2	Trigger retainer		1	3376 6081 68
3	Spool		1	3376 6081 66
4	Spring		1	3378 5120 30
5	Bearing		1	3378 5120 13
6	Circlip	H4	1	3378 5120 63
7	O-ring	Ø16 x 2 mm (0.63 x 0.08 in.)	1	3377 0005 33
8	O-ring	Ø16 x 1.5 mm (0.63 x 0.06 in.)	1	3371 8207 26
9	O-ring	Ø2 x 1.5 mm (0.08 x 0.06 in.)	1	3378 5120 37
10	O-ring	Ø6 x 2 mm (0.24 x 0.08 in.)	1	3371 8177 57

## Core bits (Thread size 1<sup>1</sup>/<sub>4</sub> in. UNC)

### Metric

Description	Core bit size (mm)	L (mm)	Wt (kg)	Remark	Part number
Diamond core bit	Ø62	450	1.7	Concrete, reinforced concrete and brickwork	3378 0050 61
Diamond core bit	Ø82	450	2.4	Concrete, reinforced concrete and brickwork	3378 0050 62
Diamond core bit	Ø102	450	3.2	Concrete, reinforced concrete and brickwork	3378 0050 63
Diamond core bit	Ø112	450	3.7	Concrete, reinforced concrete and brickwork	3378 0050 64
Diamond core bit	Ø132	450	4.6	Concrete, reinforced concrete and brickwork	3378 0050 65
Diamond core bit	Ø152	450	6.0	Concrete, reinforced concrete and brickwork	3378 0050 66
Diamond core bit	Ø162	450	6.3	Concrete, reinforced concrete and brickwork	3378 0050 67
Diamond core bit	Ø200	450	9.9	Concrete, reinforced concrete and brickwork	3378 0050 68

### Imperial

Description	Core bit size (in.)	L (in.)	Wt (lb)	Remark	Part number
Diamond core bit	Ø2 <sup>1</sup> / <sub>16</sub>	18	3.75	Concrete, reinforced concrete and brickwork	3378 0050 61
Diamond core bit	Ø3 <sup>1</sup> / <sub>4</sub>	18	5.30	Concrete, reinforced concrete and brickwork	3378 0050 62
Diamond core bit	Ø4	18	7.05	Concrete, reinforced concrete and brickwork	3378 0050 63
Diamond core bit	Ø4 <sup>3</sup> / <sub>8</sub>	18	8.16	Concrete, reinforced concrete and brickwork	3378 0050 64
Diamond core bit	Ø5 <sup>1</sup> / <sub>4</sub>	18	10.14	Concrete, reinforced concrete and brickwork	3378 0050 65
Diamond core bit	Ø6	18	13.23	Concrete, reinforced concrete and brickwork	3378 0050 66
Diamond core bit	Ø6 <sup>3</sup> / <sub>8</sub>	18	13.90	Concrete, reinforced concrete and brickwork	3378 0050 67
Diamond core bit	Ø8	18	21.83	Concrete, reinforced concrete and brickwork	3378 0050 68

Description	Remark	Quantity	Part number
Adaptor	½ in. BSP x 1¼ UNC	1	3378 5120 64



## Kits

### Seal kit

Description	Remark	Quantity	Part number
<b>Seal kit</b>		1	3376 6080 08
Dust seal	ø35 x 52 x 7 mm (ø1.38 x 2.05 x 0.28 in.)	1	3376 1007 21
Shaft seal	ø25 x 47 x 6 mm (ø0.98 x 1.85 x 0.24 in.)	1	3376 1007 20
Shaft seal	ø25 x 42 x 6 mm (ø0.98 x 1.65 x 0.24 in.)	1	3376 1007 19
O-ring	ø58 x 4 mm (ø2.28 x 0.16 in.)	1	3378 5122 79
O-ring	ø18 x 3.5 mm (ø0.71 x 0.14 in.)	2	3378 5120 35
Seal ring	Bonded seal ½ in. bsp	2	3371 8057 14
Seal ring	Bonded seal ¾ in. bsp	4	3377 0163 75
O-ring	ø16 x 2 mm (ø0.63 x 0.08 in.)	1	3377 0005 33
O-ring	ø16 x 1.5 mm (ø0.63 x 0.06 in.)	1	3371 8207 26
O-ring	ø6.3 x 1.8 mm (ø0.25 x 0.07 in.)	1	3378 5120 36
Stop ring		1	3378 5120 47
O-ring	ø2 x 1.5 mm (ø0.08 x 0.06 in.)	1	3378 5120 37
O-ring	ø6 x 1 mm (ø0.24 x 0.04 in.)	1	3376 1008 08
O-ring	ø16 x 2 mm (ø0.63 x 0.08 in.)	1	3377 0005 33
O-ring	ø16 x 1.5 mm (ø0.63 x 0.06 in.)	1	3371 8207 26
O-ring	ø2 x 1.5 mm (ø0.08 x 0.06 in.)	1	3378 5120 37
O-ring	ø6 x 2mm (ø0.24 x 0.08 in.)	1	3371 8177 57

### Motor seal kit

Description	Remark	Quantity	Part number
<b>Motor seal kit</b>	For hydraulic motors only	1	3371 8177 50

### Water kit

Description	Remark	Quantity	Part number
<b>Water kit</b>		1	3371 8090 02

## Chuck kit

---

Description	Remark	Quantity	Part number
Chuck kit		1	3371 8077 68



